

SABİT KANATLI PANJUR EXTERNAL LOUVERS



EXL-161



EXL-261



EXL-361



EXL-461

EXL - PRODUCT SPECIFICATIONS:

- Standard Material: Aluminum Profile.
- Used for fresh air returns, air exhausts, places where natural ventilation is needed and air volume control and orientation are not.
- Has three models: Z-type Standard Bladed (EXL-161), Curvilinear type Standard Bladed (EXL-261), Z- Type Wide Bladed (EXL-361) and Circular External Louver (EXL-461).
- Standard blade frame width is 32.5mm. On request, frame width can be used up to 22mm. Large blade frame is 45mm.
- Mounted with 4 mm screws with appropriate quantity.
- On request, wire mesh can be added on backside for keeping away from dusts and insects
- Electrostatic powder coating(oven-drying) with the colour from RAL catalogue.

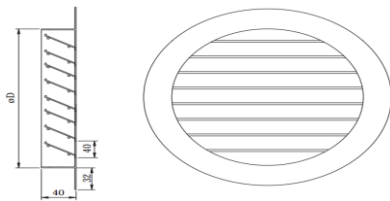
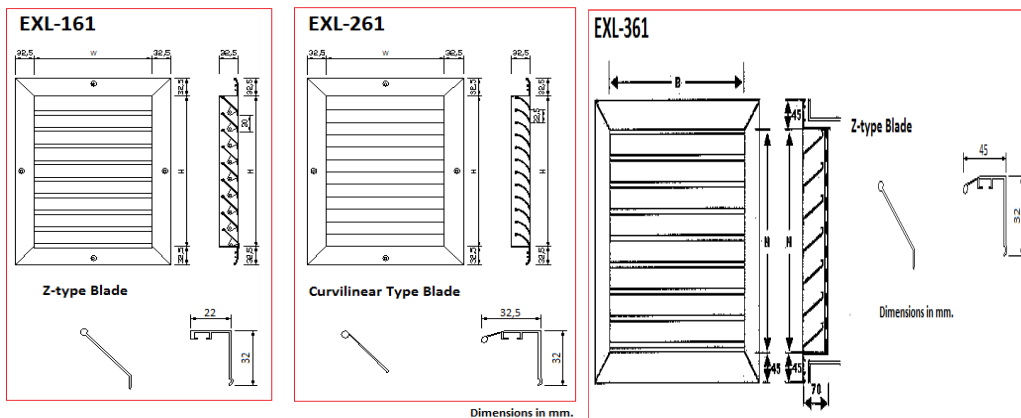

EXL-461

